

ARC DETECTOR

MC2_98 15/11/02

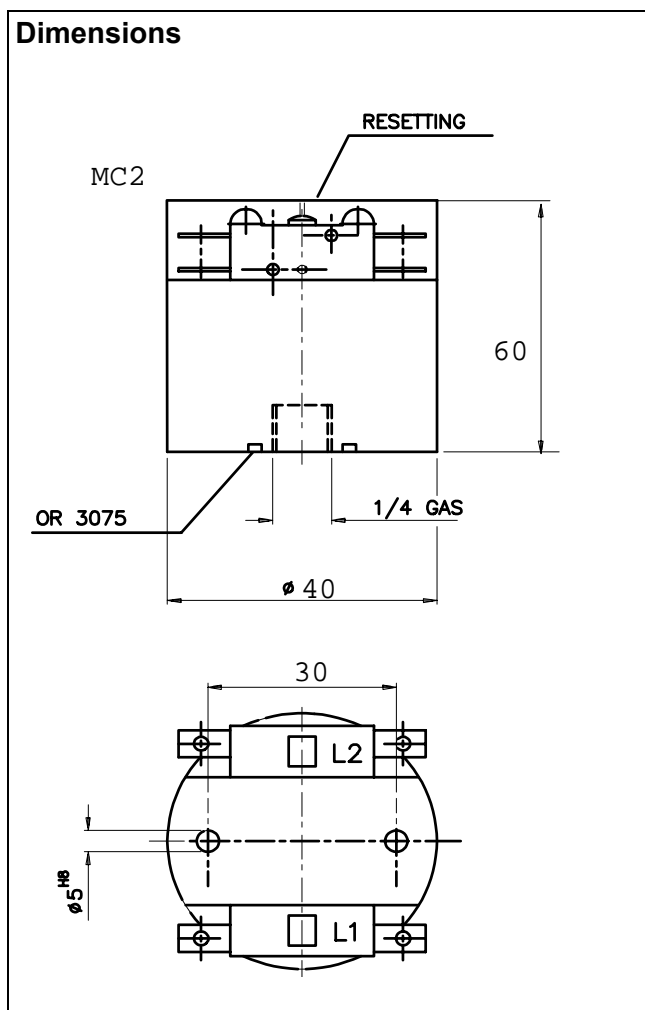

MC2

- One points overpressure controller
- Two connections for each point
- Factory calibration
- Any mounting position
- Automatic cut-off valve (patented)
- Faston 6,3 x 0,8
- Connections:

Electronsystem MD srl

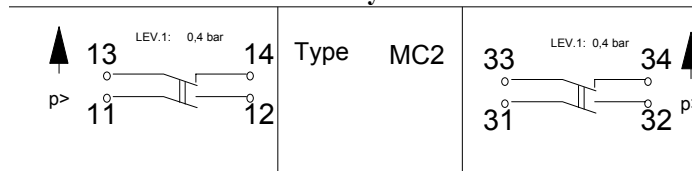

Mechanical and physical characteristics

Calibration range 0,3 - 8 bar
 Maximum pressure transient amplitude6-25 bar*
 Mechanical protection of active components.....IP 54
 Operating temperature range..... -20° + 85° C*
 Maximum fluid loss (sensor mounted on gas containers).....1 x 10⁻⁹ mbar lt/sec
 Switching level tolerance...±10% of calibration value *
 Compatibility with corrosive fluids (particularly SF6 and its derivates)
 Manual resetting
 *Versions with customized features can be provided

Security actuator for checking of fluid flux; particularly it is suitable for sensing pressure fast transient, even shorter than 10 m/s. It operates directly on control circuits to inhibit instantly the cause of disturbance.

APPLICATION RANGE

Characteristics of this sensor make it suitable for industrial systems where spontaneous ignitions or explosions with pressure elevation can take place. A cut-off valve is supplied to use the sensor in containers under pressure. This valve makes it possible to install and remove the sensor without altering conditions of the ambient where the sensor is installed. Altering switching levels according to the insulating medium (gas or air), this sensor can prevent and limit thermal shock and short circuit within electric systems. Moreover it is possible to use two different switching levels to operate a double protection:

in case of overheating the lowest threshold sends an alarm signal; in case of explosion for internal arc or other phenomena, characterised from pressure wave with steep front, the highest threshold sends a block signal.

Microswitch characteristics

Minimum time to failure of microswitch10 MIO
 Switching capability (IEC 947-5-1).....6000 cycles

| Voltage, V dc | Inductive load DC14 | Resistive load DC12 |
|---------------|---------------------|---------------------|
| 24 | 10 A | 16 A |
| 48 | 2 A | 2,5 A |
| 110/127 | 0,5 A | 0,8 A |
| 220/250 | 0,3 A | 0,6 A |

| Voltage, V ac | Inductive load AC14 | Resistive load AC12 |
|---------------|---------------------|---------------------|
| 48 | 1,5 A | 20 A |
| 110/127 | 0,6 A | 16 A |
| 220/250 | 0,3 A | 16 A |
| 320/440 | 0,2 A | 12 A |

Approvals: ASE, CSA, UL, UTE, VDE.

Electrical insulation characteristics

Isolation level to ground.....3 kV 50 Hz x 1'
 Isolation level between contacts.....1.5 kV 50 Hz x 1'