

## EFI/W/F



### Application

Fault circuit indicators are used to detect earth faults in medium voltage net: a change-over contact is used to remote the over-current tripping while a local flag indicator is used to select the faulted area of the net.

The high sensitivity of earth fault indicators allow to use them in the most typical application.

Connection between tripping device and earth current sensor is made by electrical cables suitable to be used in tropical environments.

Device is normally energized by 230-240Vca aux while the energy to trip the remote indication relay and manual reset is stored by internal li-ion battery (15 years is the estimated life time).

A diagnostic test can be performed locally by pressing a push-button. Reset can be performed locally by a second push button or by a remote command.

The device keeps the remote fault indication during the whole timing before reset. The local flag indicator always lasts the whole timing before reset.

The operating points for earth fault are adjusted with a threshold level electronic. When the current exceeds the pre-adjusted threshold level, a signal is sent to the reading instrument for evaluation. Automatic reset is possible either after elapsing of internal timer or after AUX restoring; a system to prevent false indication due to inrush current (after AUX restoring), disable sensing circuit for some seconds.

### Highlights

- Earth fault passage indicator combined
- Automatic and manual reset
- Front push button for test and reset
- Selectable earth fault trip currents
- Long lasting li-ion battery for stand alone service during fault condition (up to 50 hours)
- Remote indication by change-over contact for fault condition
- External reset with dry contact or external AUX restoring
- System to prevent false indication due to inrush current after 230Vca restoring
- Selectable rise time before fault remoting
- Output suitable for blinking lamp indicator

### Functions

Minimum impulse adjustment: the reading instrument is equipped with a setting for minimum impulse duration. The impulse picked up from the sensor is evaluated for its duration. If the impulse length is shorter than the adjusted value for the minimum impulse duration, no fault will be indicated. If the impulse duration is longer than the pre-adjusted duration, an earth fault circuit will be indicated.

Test: a push button on front panel allows to verify all the functions are ready to run. Pressing "test" also the remote relay will change state. Test can be done only if start-up "smile" indication appears on flag indicator.

Reset: the reset of the earth fault or short circuit can be done over:

- a) automatic reset: a time element controls the indication and resets it after a pre-adjusted time (4h or 6h)
- b) manual reset by a push-button on front
- c) external reset by connecting together pins 1-2
- d) external reset with AUX restoring pins L - N and delayed filter

Fault indication: two type of faults can be detected:

earth fault: must be detected connecting a three-phase current transformer on input phase L2. If the current is above threshold a flag indicator trips.

# FAULT CIRCUIT INDICATORS

EFI/W/F rev.A 26.06.09

## Material and dimensions

**Box** :..... polycarbonate  
**Mounting**:.....wall mounting  
**Dimensions** :.....wxdxh=94x130x57mm

## Relè data

### RELAY features

**Contacts Material** :.....Ag-Gold plated  
**Nominal Value** :.....0.5A 125VAC (cosφ=1.0)  
:.....1A 30VDC  
**Max changeover current** :.....1 A  
**Max changeover voltage** :.....125 VCA, 110VDC  
**Electric live** :.....1A/30 VDC cosφ1 2 x 10<sup>5</sup> cycles  
**Mechanical live** :.....1 x 10<sup>6</sup> cycles  
**Dielectric strength (open contacts)** :.....300VAC 1min  
(coil-contacts) :.....1000VAC 1min  
**Surge strength** :.....min 1500V/1.2X50us

## Filtering

**Pick up times (dip switch)** :.....40, 60, 80, 160ms  
**Inrush current time**:.....<15s  
**Reset after 230Vca restoring**:.....20s

## Technical Data

**Inputs** :..... earth current transformer  
**AUX power**:..... powered by 230-240Vca  
:.....internal li-ion battery (replaceable)

**Power consumption**:.....<20uA (stand-by mode)  
**Trip indication**:.....Flag indicator  
:.....RED fault, BLACK no fault

### Outputs

- earth fault: 1 change over contact,
- source for external blinking lamp

### Current transformer sensors:

- earth fault: 3 phases laminated transformer plates with coil, electrical cable

### Threshold fault current:

- earth fault:..... 30, 40, 50, 60A user selectable\*\*

**Accuracy**:.....+/- 10%

**Test**:.....manual test on front panel

**Reset** : .....manual, automatic (4, 6hours\*\*)

.....dry contact external reset

.....AUX restoring reset

**Temperature range** :..... -30°C ÷ 60°C

### Protection class

- control unit.....IP54
- current transformers sensors:.....IP67

(\*\*)Other values can be chosen by special request

# FAULT CIRCUIT INDICATORS

EFI/W/F rev.A 26.06.09

Rev./Mod Descrizione:	Data	Rev./Mod Descrizione:	Data	Rev./Mod Descrizione:	Data	Rev./Mod Descrizione:	Data	Rev./Mod Descrizione:	Data
Piano di Compimento (UNI 4842-75)		LIVELLO		LOA		L2		1	

Fig.	Materiali/Materiale		N° Series / Serie	Finishing / Finitura	*OPTIONAL
Filing Room Archivio	Thread quality tolerance Tolleranza filetti: qualità "6g-5S" UNI 5541-65	General tolerance for machining / Tolleranze generali per lavorazioni meccaniche: Coord. Punching N.C. mach. Coord. punzon. a CN. JS11	Quality for linear dimension Qualità per quote lineari: JS11	Extra-fine / Fine Medion / Media Coarse / Grossolana JS12 JS13 JS15	
Prep. G. FORLANI App. P. GUIZZETTI	Resp. Dep. Uff. Resp.	Uff. Tecnico	Title Titolo	EARTH FAULT INDICATOR EFI/W/F	Lang. Lingua
Rev./Mod.	0   05.06.2009 : Emissione nuovo disegno	Appartus Apparecchio	Doc. No. N° Doc.	43911026	Scale Scala
<b>ELECTRONSYSTEM MD S.r.l.</b>			1 : 1 SN No. 1 / 2		

# FAULT CIRCUIT INDICATORS

EFI/W/F rev.A 26.06.09

Rev./Mod	Data	Rev./Mod	Data	Rev./Mod	Data	Rev./Mod	Data				
Descrizione:		Descrizione:		Descrizione:		Descrizione:					
<b>TECHNICAL DATA</b>											
<ul style="list-style-type: none"> <li>-Inputs: electrical earth sensor remote contact for reset</li> <li>-Power: 230Vac 240Vac aux Internal 1100mAh battery (replaceable)</li> <li>-Flag Indicator: RED fault, BLACK no fault</li> </ul>											
<div style="display: flex; align-items: center; justify-content: center;"> <div style="border: 1px solid black; border-radius: 50%; width: 20px; height: 20px; margin-right: 5px;"></div> <span>FAULT</span> </div>											
<ul style="list-style-type: none"> <li>-Outputs: 1 change over contact for fault detection power source for blinking lamp</li> <li>-Current transformer sensors: for earth fault, laminated plates coils with electrical cable 20m</li> <li>-Trip current: 30, 40, 50, 60A selectable for earth fault**</li> <li>-Accuracy: +/- 10%</li> <li>-Pick up times (Impulse duration): 40, 60, 80, 160 msec</li> <li>-Reset: manual, automatic (4, 6hours) dry contact external reset AUX restoring reset</li> <li>-Temperature range: -30°C + 60°C</li> <li>-Protection class: din rail mounted instrument IP54</li> </ul>											
<b>RELAY FEATURE</b>											
<ul style="list-style-type: none"> <li>-Contacts Material: Ag-Gold plated</li> <li>-Nominal Value: 0,5A 125Vac (cosφ=1,0) 1A 30Vdc</li> <li>-Max changeover current: 1A</li> <li>-Max changeover voltage: 125 Vac, 110Vdc</li> <li>-Electric life: 1A/30Vdc cosφ 1 2 x 10<sup>4</sup> cycles</li> <li>-Mechanical life: 1 x 10<sup>6</sup> cycles</li> <li>-Dielectric strength (open contacts): 300Vac 1min (coil-contacts) : 1000Vac 1min</li> <li>-Surge strength: min 1500V/1,2x50us</li> </ul>											
<p>(**) Other values can be chosen by special request</p>											
<p>Piano di Compiimento (UNI 4842-75)</p> <table border="1" style="width: 100%; border-collapse: collapse;"> <tr> <td style="width: 50%;">LIVELLO</td> <td style="width: 50%;">LOA</td> </tr> <tr> <td style="text-align: center;">L2</td> <td style="text-align: center;">1</td> </tr> </table>								LIVELLO	LOA	L2	1
LIVELLO	LOA										
L2	1										
<p>© riserviamo tutti i diritti connessi con il presente documento e con l'oggetto o la materia ivi rappresentati con divieto di riproduzione, utilizzo o rendito accessibile a terzi in assenza di previa autorizzazione.</p>											

## DIP-SWITCH SELECTION DP1:

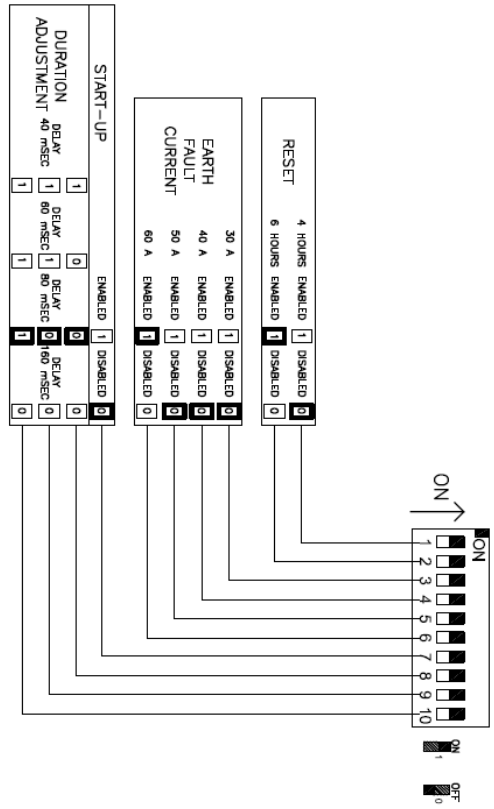

## CONNECTORS

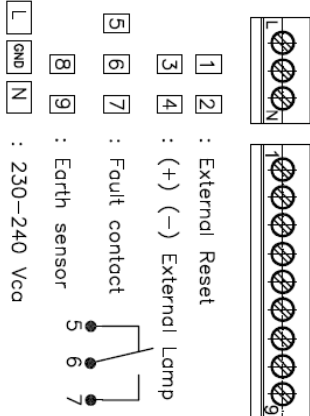

### ORDERING CODE:

Code : EFI/W/F

NOTE: - Default dip-switch configuration is marked by bold square

Fig.	Material/Materiale	N° Series / Serie	Finishing / Finitura
Filing Room Archivio	Thread quality tolerance Tolleranza filetti: qualità "Bg-5S" UNI 5541-65	General tolerance for machining / Tolleranze generali per lavorazioni meccaniche:	JS12 JS13 JS15
Prep. G. FORLANI	Coord. Punzoni, o C.N. JS11	Quality for linear dimension Qualità per quote lineari:	JS12 JS13 JS15
App. P. GUIZZETTI	Resp. Dep. Uff. Resp. Uff. Tecnico	Title EARTH FAULT INDICATOR	Scale 1:1
Rev./Mod. 0105.06.2009	Emissione nuovo disegno	Appartus Appreccio	Scale 1:1
<b>ELECTRONSYSTEM MD S.r.l.</b>		Doc. No. 43911026	Scale 2/2

# FAULT CIRCUIT INDICATORS

EFI/W/F rev.A 26.06.09

Rev./Mod Descrizione:	Data	Rev./Mod Descrizione:	Data	Rev./Mod Descrizione:	Data	Rev./Mod Descrizione:	Data
NOTE: -SUITABLE FOR CABLE WITH MAX DIAMETER OF 120 mm -OUTPUT CABLE Lx STANDARD = 2 m							
TA/EW/ length of cable in mm							
Piano di Compimento (UNI 4842-75) LIVELLO      LOA L2                      1							
We reserve all rights in this document and in the information contained therein. Reproduction, use or disclosure to third parties without express authority is strictly forbidden. Ci riserviamo tutti i diritti connessi con il presente documento e con l'oggetto o la materia ivi rappresentati con divieto di riproduzione, utilizzo o rendelo accessibile a terzi in assenza di previa autorizzazione.							
Fig. _____ Filing Room Archivio		Thread quality / tolerance Tolleranza filetti qualità *Fg-5S* UNI 5541-65		General tolerance for machining / Tolleranze generali per lavorazioni meccaniche: Coord. Punching N.C. mach. Coord. punzon. a C.N. JS11		N° Series / Serie Finishing / Finitura	
Prep. G. FORLANI App. P. GUIZZETTI		Resp. Dep. Uff. Tecnico		Title Title TA/EW		Appartus Apparecchio Dec. No. N° Doc.	
Rev./Mod. [0] 26.02.2007 : Emissione nuovo disegno		ELECTRONSYSTEM MD S.r.l.		43911033		Scale 1:1 Sp. No. 1/1	

# FAULT CIRCUIT INDICATORS

EFIW/F rev.A 26.06.09

Ci riserviamo tutti i diritti connessi con il presente documento e con l'oggetto o la materia ivi rappresentati con divieto di riprodurlo, utilizzarlo o renderlo accessibile a terzi in assenza di previa autorizzazione

We reserve all rights in this document and in the information contained therein. Reproduction, use or disclosure to third parties without express authority is strictly forbidden

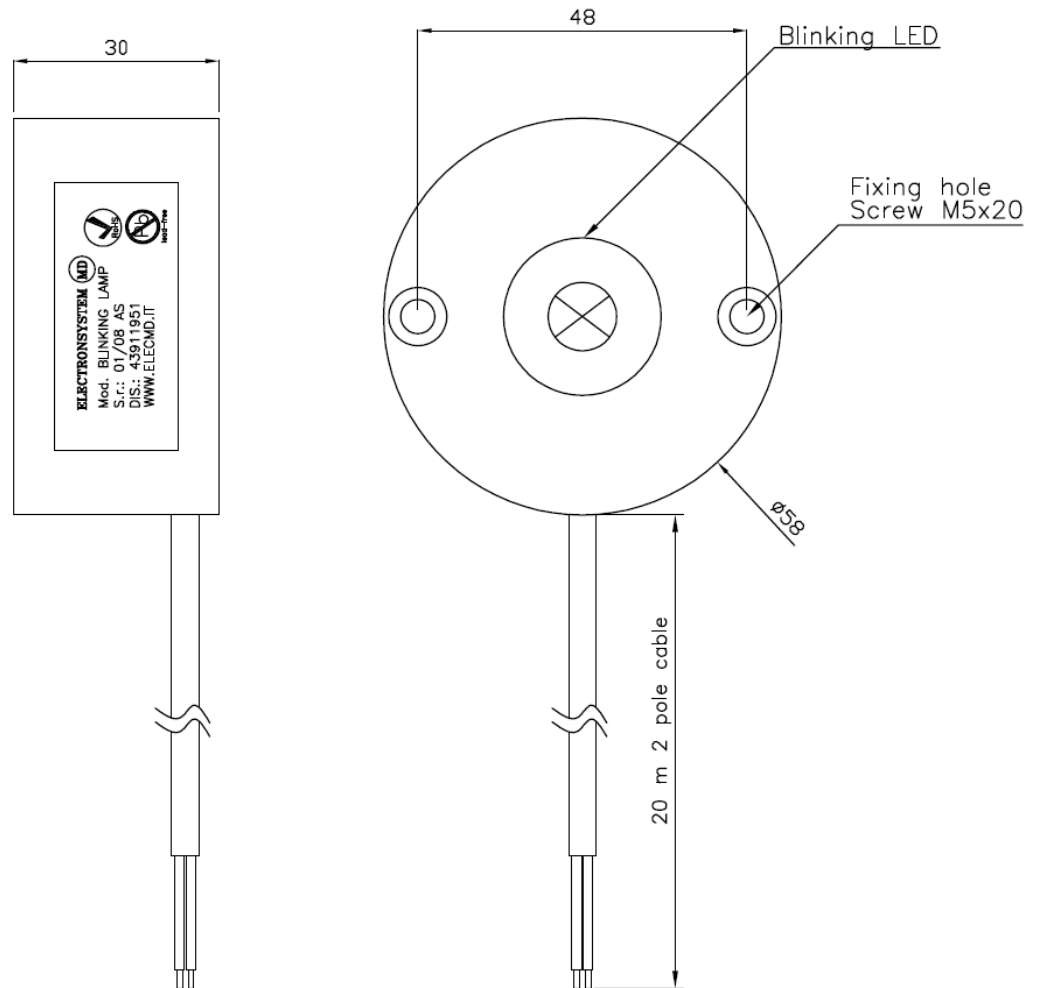
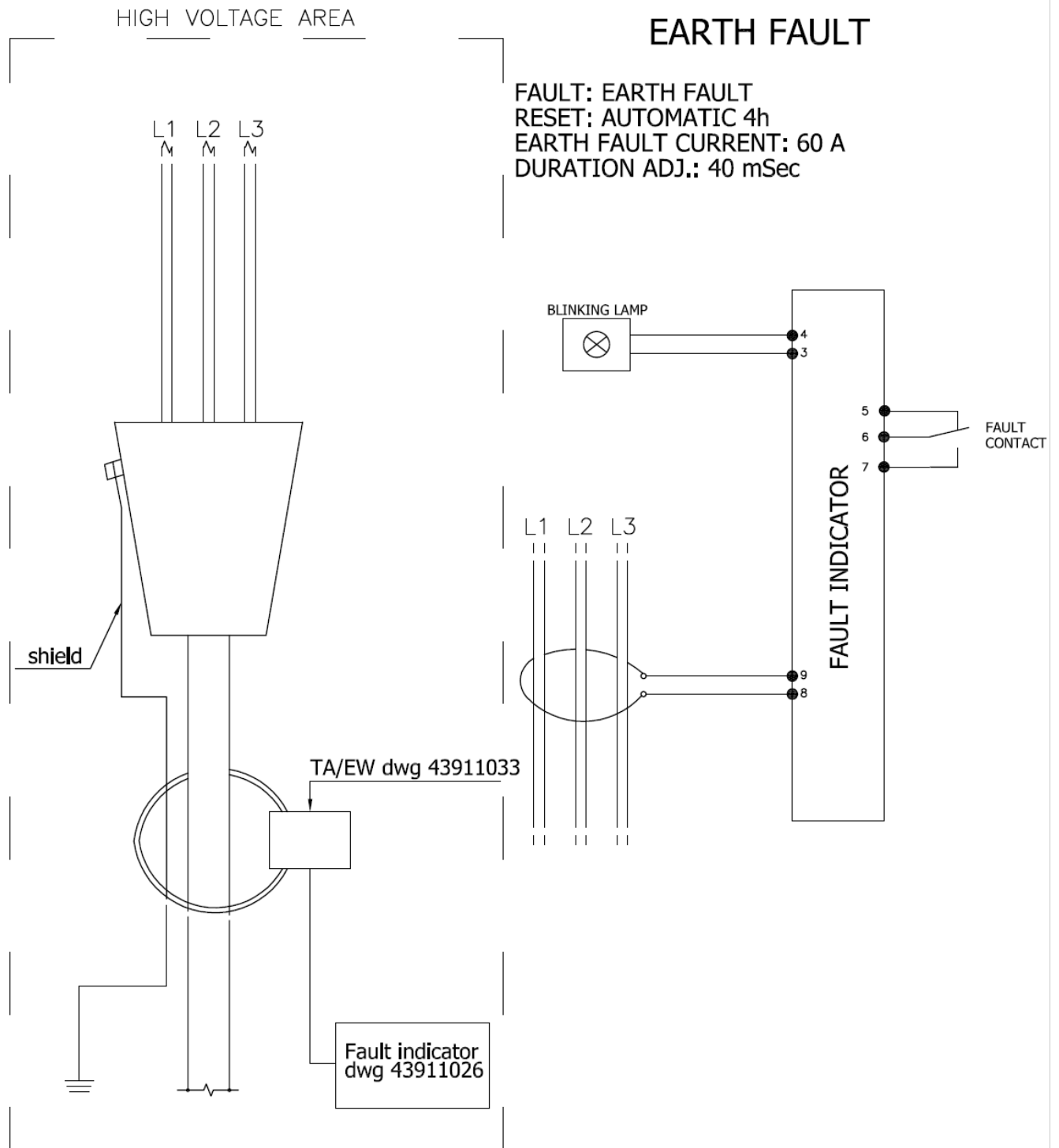

Fig.	Material/Materiale	N° Series / Serie	Finishing / Finitura						
Filing Room Archivio	Thread quality tolerance Tolleranza filetti qualita' "6g-6S" UNI 5541-65	General tolerance for machining / Tolleranze generali per lavorazioni meccaniche:							
		Coord.Punching N.C. mach. Coord. punzon. a C.N. JS11	Quality for linear dimension Qualita' per quote lineari						
			<table border="1" style="width: 100%; border-collapse: collapse;"> <tr> <td style="width: 80%;"><del>Extra fine / Fine</del></td> <td style="width: 20%; text-align: center;"><del>JS12</del></td> </tr> <tr> <td>Median / Media</td> <td style="text-align: center;">JS13</td> </tr> <tr> <td><del>Coarse / Grossolone</del></td> <td style="text-align: center;"><del>JS15</del></td> </tr> </table>	<del>Extra fine / Fine</del>	<del>JS12</del>	Median / Media	JS13	<del>Coarse / Grossolone</del>	<del>JS15</del>
<del>Extra fine / Fine</del>	<del>JS12</del>								
Median / Media	JS13								
<del>Coarse / Grossolone</del>	<del>JS15</del>								
Prep. Dis. G. FORLANI	Resp. Dep. Uff. Resp.	Title Titolo							
App. P. GUIZZETTI	Uff. Tecnico	BLINKING LAMP							
Rev./Mod	0   23.01.2008 : Emissione nuovo disegno	Apparatus Apparecchio	Scale Scala						
<b>ELECTRONSYSTEM MD S.r.l.</b>		Doc. No. N° Doc.	Sh.No. N° Pag. 1/1						
		43911951							

## INSTALLATION EXAMPLE



The reading instruments has to be installed outside the high voltage area.  
It is possible to install the short circuit sensors on screened and unscreened cables.  
The earth fault sensor must be installed around all three cores to assure that the sum current of all the three cables is picked up.  
The frames of the sensors can be opened for installation.

## OPERATING DIAGRAMS WITH FAULTY LINE

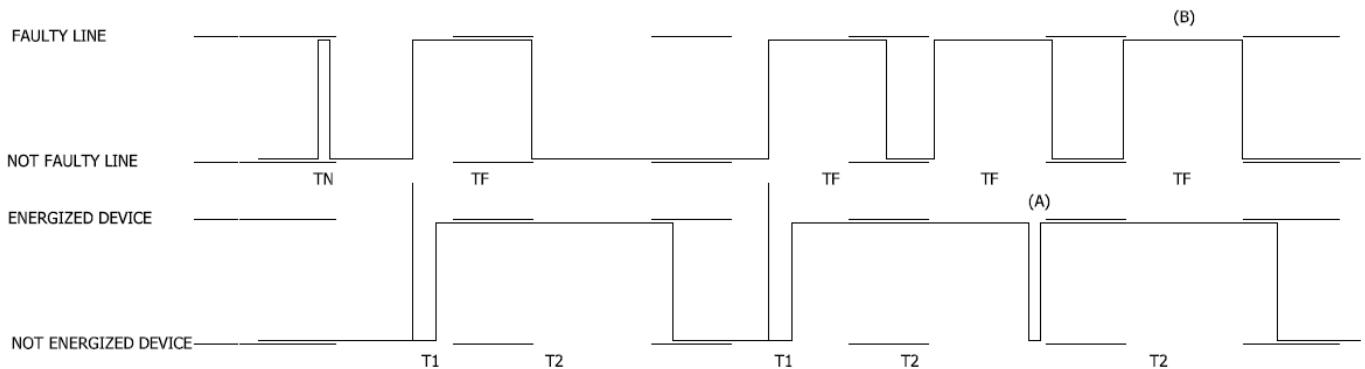
**COMMENTS:**

TN: NOISE DURATION &lt; T1

TF: FAULT DURATION

T1: FILTER DURATION SET BY DIP-SWITCH

T2: AUTOMATIC RESET DURATION SET BY DIP-SWITCH

(A) IN CASE OF RESET WITH STILL FAULTY LINE THE DEVICE ENERGIZES AGAIN

(B) IN CASE OF NEW FAULT WITH ALREADY ENERGIZED DEVICE NOTHING HAPPENS

## OPERATING RESET DIAGRAMS

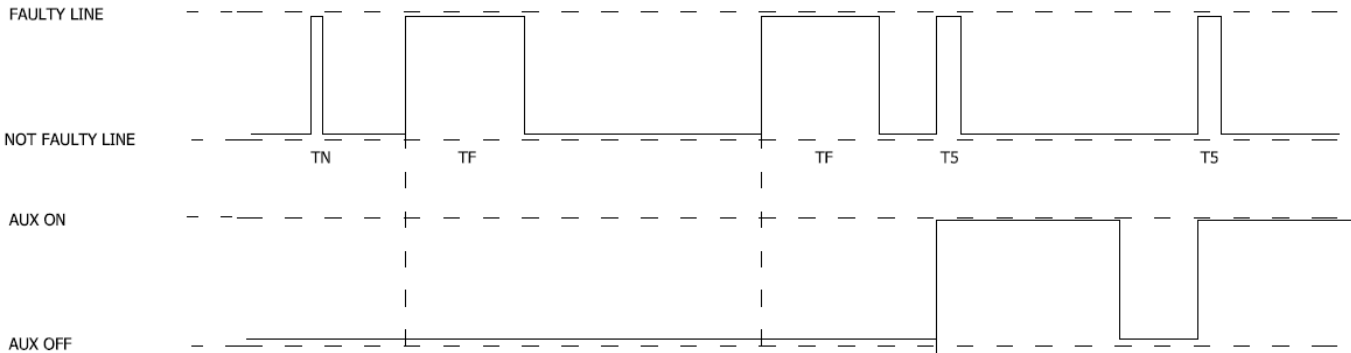

### (1) AUTOMATIC RESET

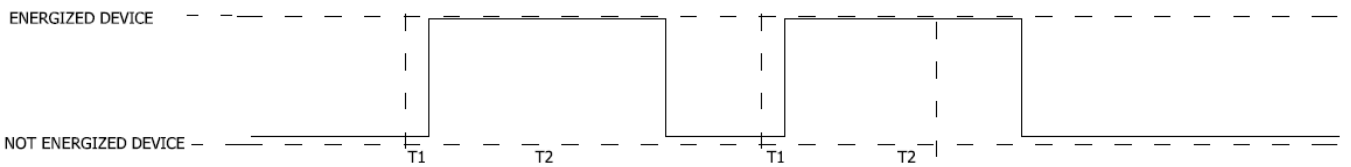

### (2) MANUAL/EXTERNAL RESET

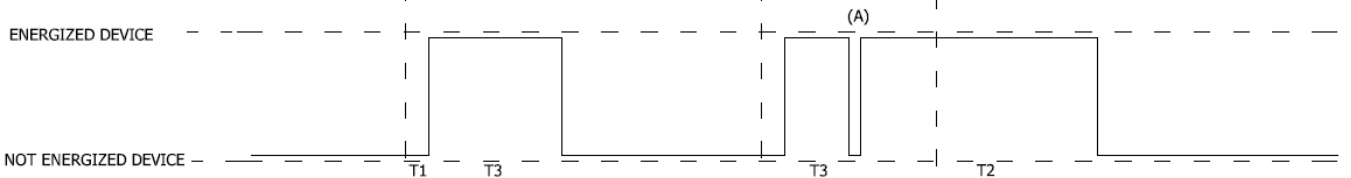

### (3) AUX RESTORING

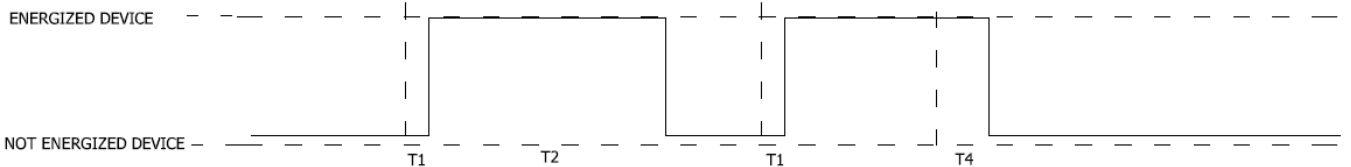

**COMMENTS:**

- TN: NOISE DURATION <math>< T1</math>
- TF: FAULT DURATION
- T1: FILTER DURATION SET BY DIP-SWITCH
- T2: AUTOMATIC RESET DURATION SET BY DIP-SWITCH
- T3: RANDOM DURATION OF MANUAL OR EXTERNAL RESET
- T4: DELAY OF RESET AFTER AUX RESTORING; ABOUT 5s
- T5: INRUSH CURRENT AFTER AUX RESTORING <math>< T4</math>
- (A) IN CASE OF RESET WITH STILL FAULTY LINE THE DEVICE ENERGIZES AGAIN

## MAINTENANCE SPECIFICATIONS

### KIT ASSEMBLIES

Nº1 EFI/W/F DWG. 43911026

Nº1 TA/EW DWG. 43911033

Nº1 BLINKING LAMP DWG. 43911951

### STORAGE

If the complex must be storage before use, please keep dry and repaired from cold and hot climates, respecting the original position of case. Move and take care to prevent injuries.

OPERATING TEMPERATURE RANGE:  $-30^{\circ}\text{C} \div +70^{\circ}\text{C}$

STORAGE TEMPERATURE:  $-40^{\circ}\text{C} \div +85^{\circ}\text{C}$

RELATIVE HUMIDITY: 95% @  $+40^{\circ}\text{C}$

### BATTERY SPECIFICATIONS

TYPE: ER14505 Lithium thionyl chloride battery

NOMINAL CAPACITY: 2200mAh

NOMINAL VOLTAGE: 3,6 Vdc

STANDARD DISCHARGE CURRENT: 2mA

MAXIMUM CONTINUOUS CURRENT: 100mA

MAXIMUM PULSE CURRENT: 200mA

OPERATING TEMPERATURE RANGE:  $-30^{\circ}\text{C} \div +85^{\circ}\text{C}$

STORAGE TEMPERATURE:  $+30^{\circ}\text{C}$  Max (recommended)