

FAULT CIRCUIT INDICATORS

FI/X/X



FI/X/L LATCHED RELAY TYPE

FI/X/S STABLE RELAY TYPE

Highlights

- Phase to phase fault indicator and earth fault indicator combined
- Automatic and manual reset
- Front push button for test and reset
- Selectable earth fault trip currents
- Selectable phase trip currents
- Long lasting li-ion battery for stand alone service during fault condition (up to 50 hours)
- High efficiency high resolution display for fault indication
- Remote indication by change-over contact for phase to phase or earth faults
- External reset with dry contact or 230Vca restoring
- Selectable time delay after fault detection
- Output suitable for blinking lamp indicator

Application

Fault circuit indicators are used to detect phase to phase or earth faults or short circuits in medium voltage net: a change-over contact is used to remote the over-current tripping while a local LCD display indication is used to select the faulted area of the net.

FI/X/X is able to detect both phase to phase or phase to earth faults according to current sensors used for detection: to detect earth fault situations a three phase current sensor must be used.

The high sensitivity of earth fault indicators allow to use them in the most typical application.

Connection between tripping device and current sensor is made by electrical cables.

The energy to trip the remote indication relay is derived by fault itself, while test and manual reset are energized by internal li-ion battery (10 years is the estimated life time).

A diagnostic test can be performed locally by pressing a push-button. Reset can be performed locally by a second push button or by a remote command.

The device with stable relay maintain the changeover fault indication during the whole timing before reset, the latched one lasts only for 300ms.

The local LCD indication always lasts the whole timing before reset.

The sensors detect earth faults and short circuits inductively. The operating points for earth fault and short circuit are adjusted with a threshold level electronic. When the current exceeds the pre-adjusted threshold level, a signal is sent to the reading instrument for evaluation. The respective LCD indication is activated and starts to blink.

Functions

Minimum impulse adjustment: the reading instrument is equipped with a setting for minimum impulse duration. The impulse picked up from the sensor is evaluated for its duration. If the impulse length is shorter than the adjusted value for the minimum impulse duration, no fault will be indicated. If the impulse duration is longer than the pre-adjusted duration, an earth fault or short circuit will be indicated.

Test: a push button on front panel allows to verify all the functions are ready to run. Pressing "test" also the remote relay will change state according to dip-switches selection. Test can be done only if start-up "smile" indication appears on display

Reset: the reset of the earth fault or short circuit can be done over:

- a) automatic reset: a time element controls the indication and resets it after a pre-adjusted time (2h or 4h)
- b) manual reset by a push-button on front
- c) external reset by connecting together pins 13-14
- d) external reset with 230Vca restoring pins 17-18

Fault indication: two type of faults can be detected:

- a) earth fault: must be detected connecting a three-phase current transformer on input phase L2. If the current is above threshold a lamp & earth symbol will appear on LCD display.
- b) short circuit: a single phase current transformer must be connected to each input phase. If the current is above the threshold a lamp will appear on involved phase.

Start-up: a dip switch allows to activate this function that enables power on through li-ion battery. A "smile" will appear on display indicating the device is ready to run and test or reset can be achieved. If the output sensor current is sufficient li-ion battery will be disabled. An auto-diagnostic cycle supervise the circuitry and only if everything is OK the "smile" will appear.

FAULT CIRCUIT INDICATORS

FI/XX

Rev./Mod A	Data 27.04.2007	Rev./Mod B	Data 14.04.2008	Rev./Mod C	Data 01/12/2008	Rev./Mod	Data	Rev./Mod	Data	Rev./Mod	Data
Descrizione: MODIFICHE GENERALI		Descrizione: MODIFICHE GENERALI		Descrizione: Aggiornamento lunghezza		Descrizione:		Descrizione:		Descrizione:	

ORDERING CODE:
TA/P / _____

length of cable in mm

TA CABLE DWG 43922270

double PVC 2x1mm²

-SUITABLE FOR CABLE WITH MAX DIAMETER OF 52 mm

Livello	LQA	Ci riserviamo tutti i diritti connessi con il presente documento e con l'oggetto o la materia ivi rappresentati con riguardo di riproduzione, utilizzazione o renderlo accessibile a terzi in assenza di previa autorizzazione.									
L2	1										

Filling Room Archivio	Thread quality tolerance Tolleranza filetti qualitativi "Eg-65" UNI 5541-65	General tolerance for machining / Tolleranze generali per lavorazioni meccaniche: Coord. Punching N.C. mach. Coord. punzon. a C.N. JS11	N° Series / Serie	Finishing / Finitura
Prep. G. FORLANI				
App. P. GUIZZETTI	Resp. Dep. Uff. Tecnico			
Rev./Mod.	0 26.02.2007 : Emissione nuovo disegno			
ELECTRONSYSTEM MD S.r.l.		Apparecchio	TA/P	43911905
		Doc. No. N° Doc.		Scale 1:1 R° No. 1/1

FAULT CIRCUIT INDICATORS

FI/XX

Ci riserviamo tutti i diritti connessi con il presente documento e con l'oggetto o la materia ivi rappresentati con divieto di riprodurlo, utilizzarlo o renderlo accessibile a terzi in assenza di previa autorizzazione

We reserve all rights in this document and in the information contained therein. Reproduction, use or disclosure to third parties without express authority is strictly forbidden

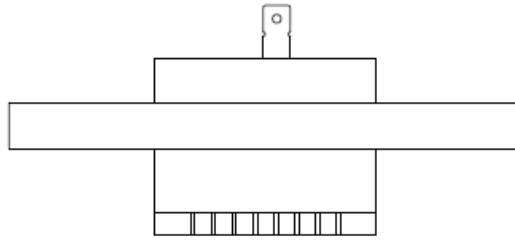

TA CABLE DWG 43922270

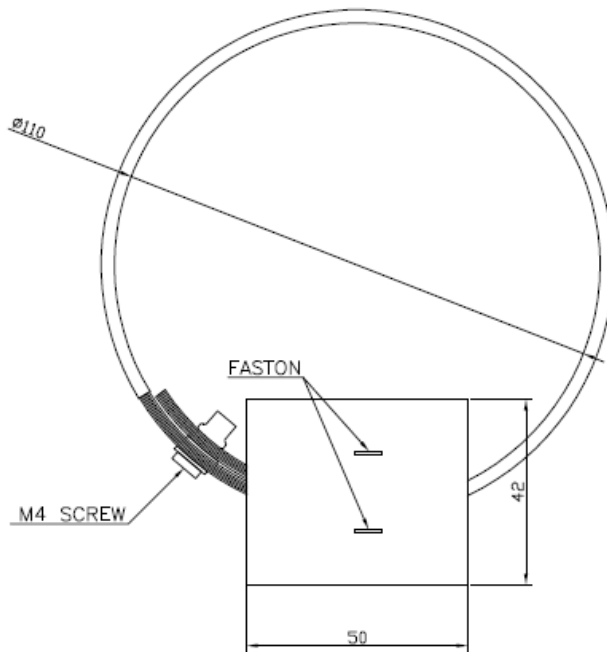

ORDERING CODE:

TA/E/

length of cable in mm

double PVC 2x1mm²

-SUITABLE FOR CABLE WITH MAX DIAMETER OF 110 mm

LYNER PVC CON BIADESIVO					
Fig.	Material/Materiale	N° Series / Serie	Finishing / Finitura		
Filing Room Archivio	Thread quality tolerance Tolleranza filetti qualita' "6g-6S" UNI 5541-65	General tolerance for machining / Tolleranze generali per lavorazioni meccaniche:			
		Coord.Punching N.C. mach. Coord. punzon. a C.N. JS11	Quality for linear dimension Qualita' per quote lineari	Extra fine / Fine	JS12
				Median / Media	JS13
				Coarse / Grossolano	JS15
Prep. Dis. G. FORLANI	Resp. Dep. Off. Resp. Uff. Tecnico		TA/E		⊕
App. P. GUIZZETTI					Lang. Lingua
Rev./Mod	0 05.03.2008 : Emissione nuovo disegno		Apparatus Apparecchio		Scale Scala
ELECTRONSYSTEM MD S.r.l.			43911906		Sh.No. N° Pag. 1/1

FAULT CIRCUIT INDICATORS

FI/X/X

Ci riserviamo tutti i diritti connessi con il presente documento e con l'oggetto o la materia ivi rappresentati con divieto di riprodurlo, utilizzarlo o renderlo accessibile a terzi in assenza di previa autorizzazione

We reserve all rights in this document and in the information contained therein. Reproduction, use or disclosure to third parties without express authority is strictly forbidden

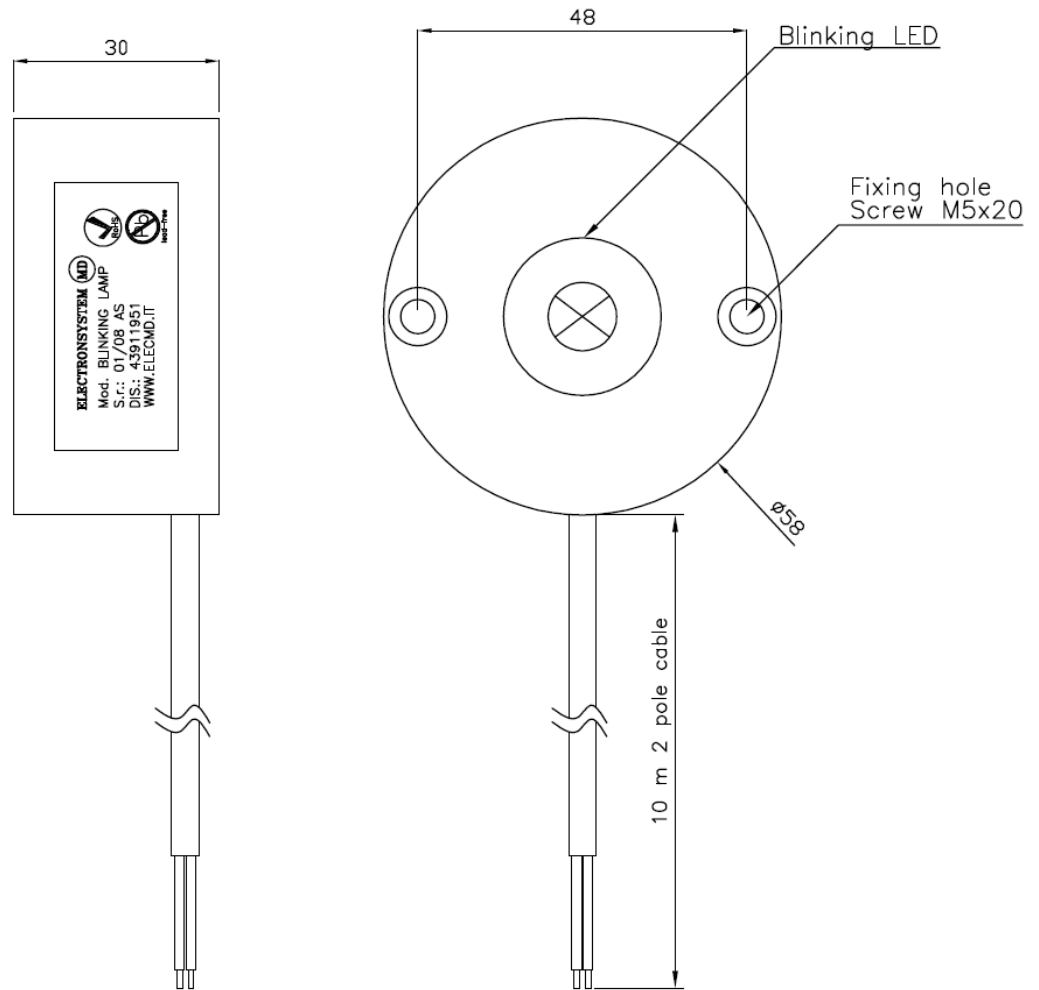
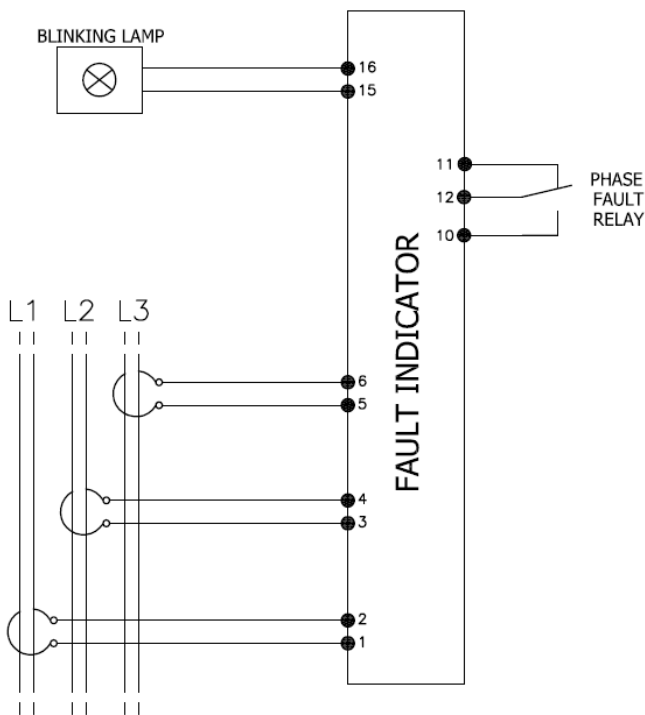

Fig.	Material/Materiale	N° Series / Serie	Finishing / Finitura						
Filing Room Archivio	Thread quality tolerance Tolleranza filetti qualita' "6g-6S" UNI 5541-65	General tolerance for machining / Tolleranze generali per lavorazioni meccaniche: Coord.Punching N.C. mach. Coord. punzon. a C.N. JS11	<table border="1" style="width: 100%; border-collapse: collapse;"> <tr> <td>Extra fine / Fine</td> <td>JS12</td> </tr> <tr> <td>Median / Media</td> <td>JS13</td> </tr> <tr> <td>Coarse / Grossolana</td> <td>JS15</td> </tr> </table>	Extra fine / Fine	JS12	Median / Media	JS13	Coarse / Grossolana	JS15
Extra fine / Fine	JS12								
Median / Media	JS13								
Coarse / Grossolana	JS15								
Prep. Dis. G. FORLANI	Resp. Dep. Uff. Resp. Uff. Tecnico	Title Titolo BLINKING LAMP							
App. P. GUIZZETTI	Apparatus Apparecchio 43911951		Scale Scala 3/3						
Rev./Mod 0	23.01.2008 : Emissione nuovo disegno		Sh.No. Pag. 3/3						
ELECTRONSYSTEM MD S.r.l.									

APPLICATION EXAMPLE

PHASE TO PHASE FAULT

FAULT: PHASE FAULT
RESET: AUTOMATIC 4h
PHASE FAULT CURRENT: 400 A
DURATION ADJ.: 40 mSec



DIP-SWITCH CONFIGURATION

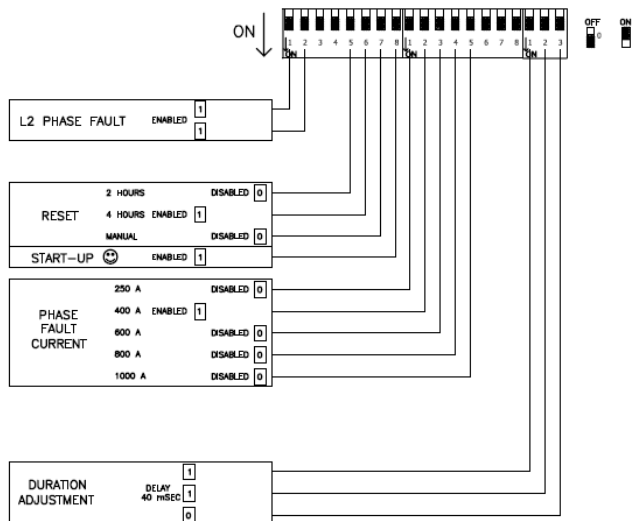

PHASE TO PHASE FAULT + EARTH FAULT

FAULT: PHASE FAULT + EARTH FAULT
RESET: AUTOMATIC 4h
PHASE FAULT CURRENT: 400 A
EARTH FAULT CURRENT: 60 A
DURATION ADJ.: 40 mSec

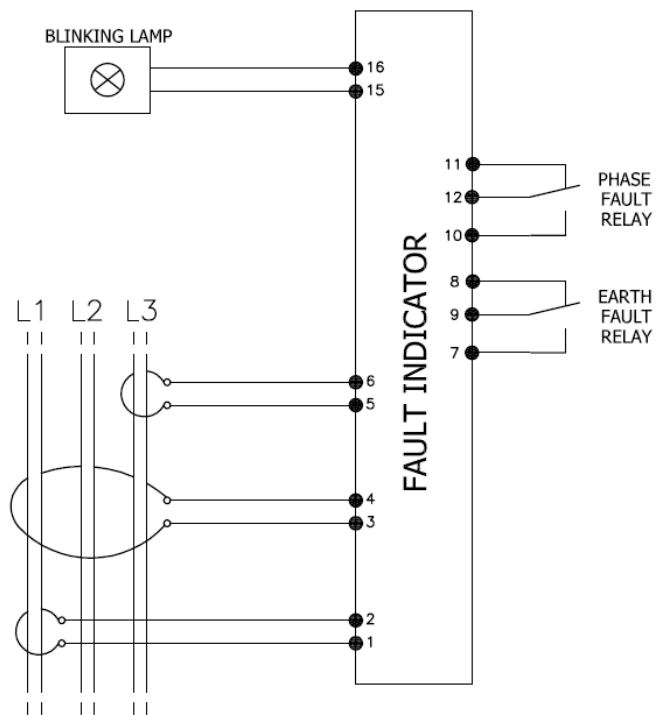

DIP-SWITCH CONFIGURATION

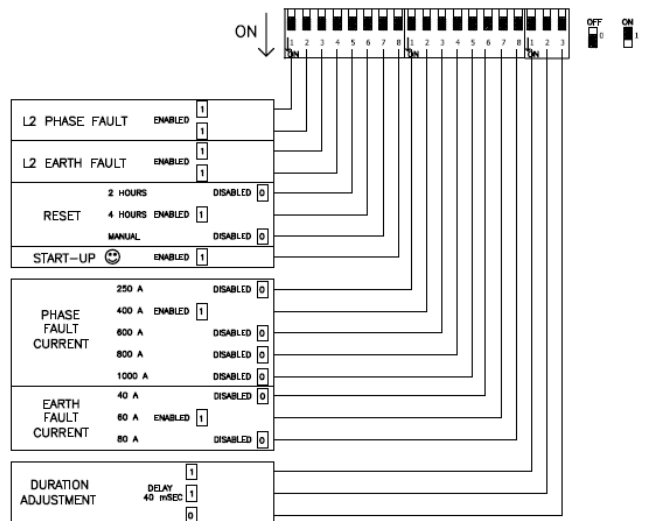

INSTALLATION EXAMPLE

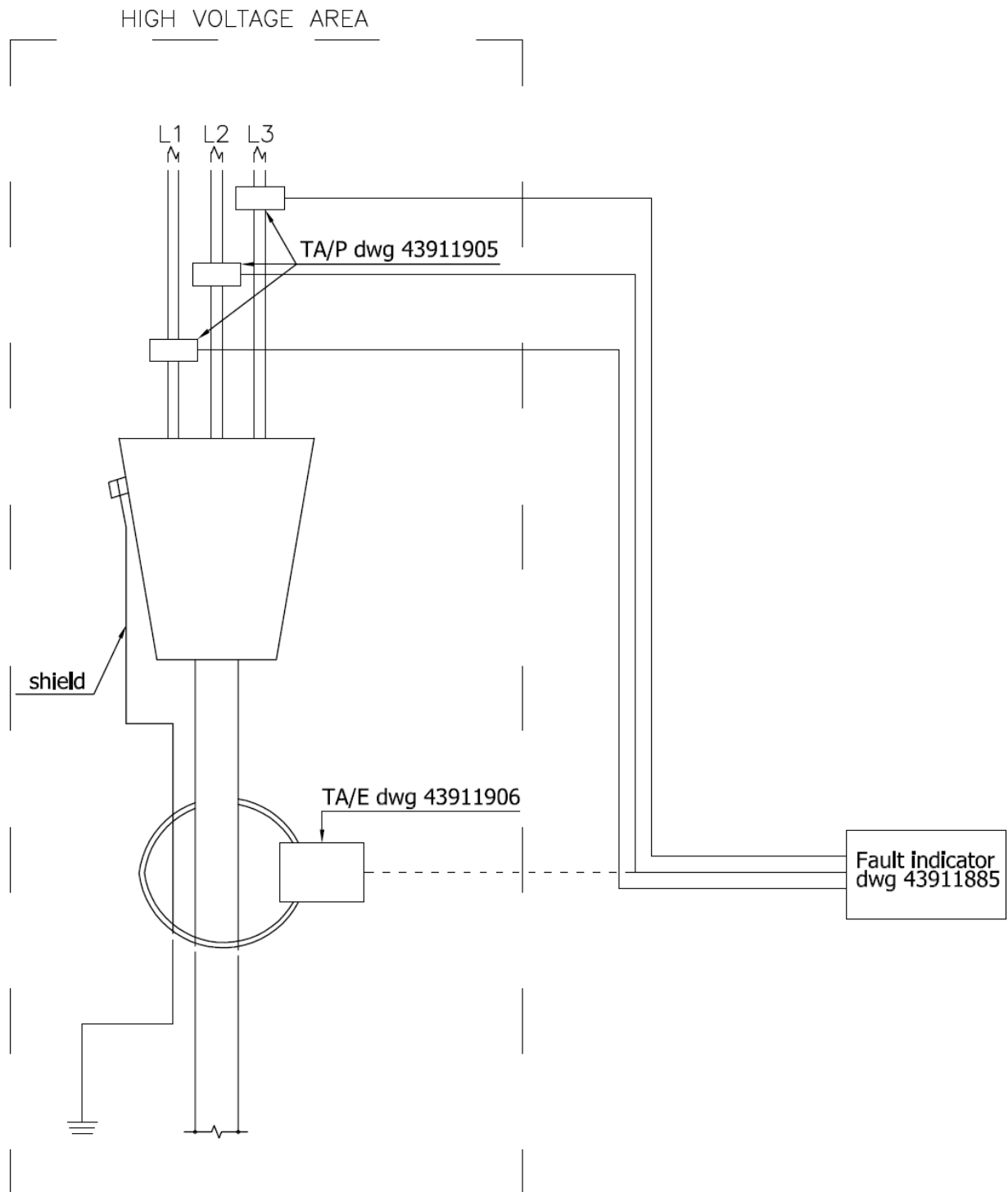

The reading instruments has to be installed outside the high voltage area.
It is possible to install the short circuit sensors on screened and unscreened cables.
The earth fault sensor must be installed around all three cores to assure that the sum current of all the three cables is picked up.
The frames of the sensors can be opened for installation.

OPERATING DIAGRAMS WITH FAULTY LINE

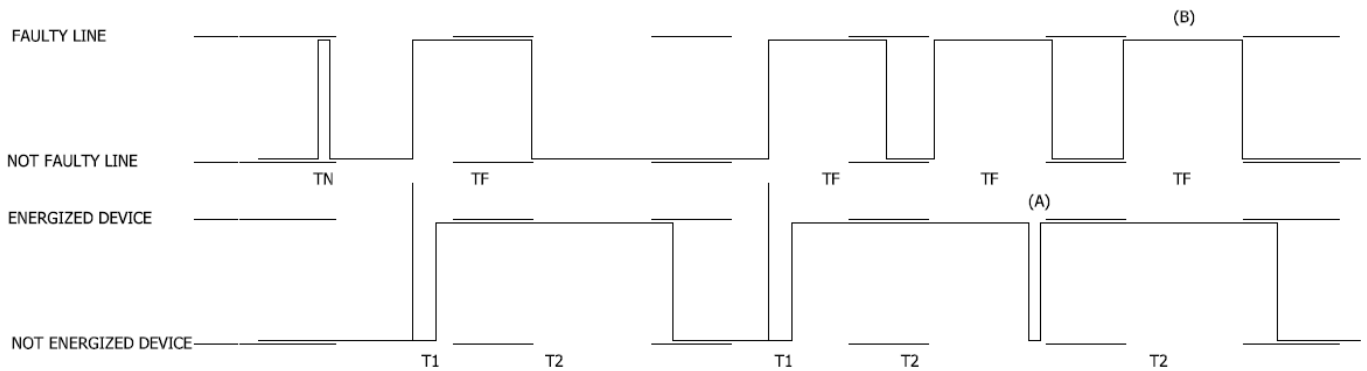
**COMMENTS:**TN: NOISE DURATION $< T1$

TF: FAULT DURATION

T1: FILTER DURATION SET BY DIP-SWITCH

T2: AUTOMATIC RESET DURATION SET BY DIP-SWITCH

(A) IN CASE OF RESET WITH STILL FAULTY LINE THE DEVICE ENERGIZES AGAIN

(B) IN CASE OF NEW FAULT WITH ALREADY ENERGIZED DEVICE NOTHING HAPPENS

OPERATING RESET DIAGRAMS

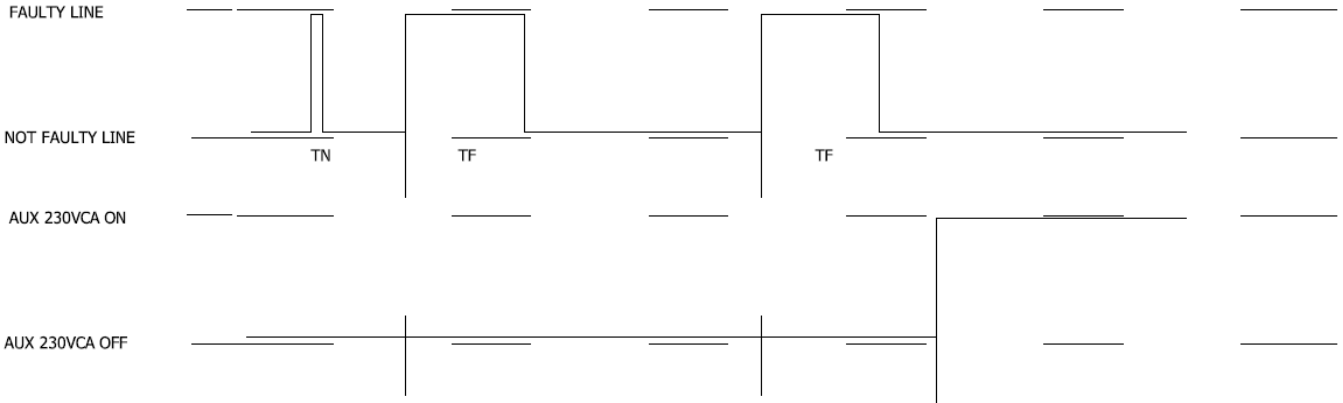

(1) AUTOMATIC RESET

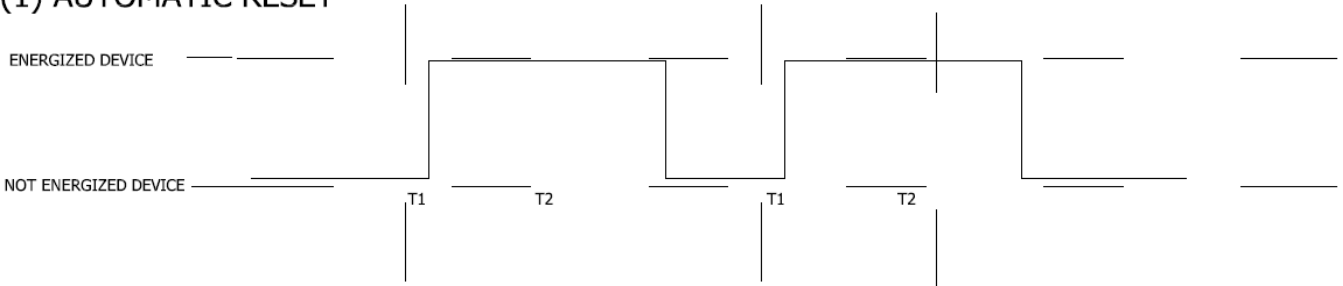

(2) MANUAL/EXTERNAL RESET

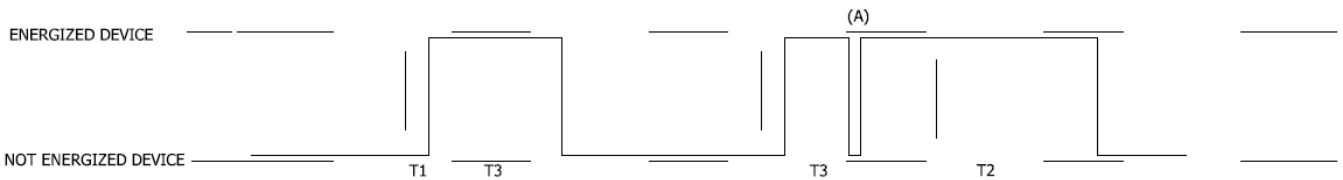

(3) 230VCA RESTORING

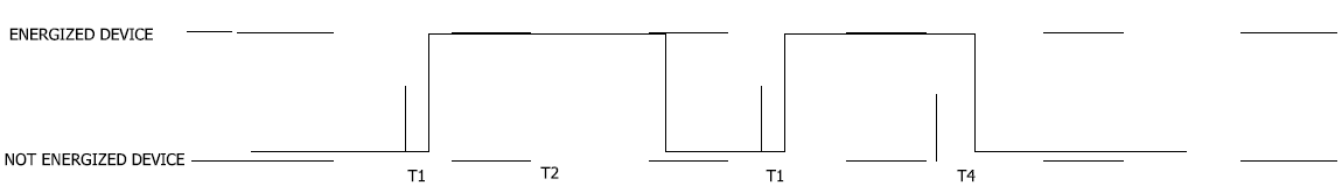

COMMENTS:

- TN: NOISE DURATION <math>< T1</math>
- TF: FAULT DURATION
- T1: FILTER DURATION SET BY DIP-SWITCH
- T2: AUTOMATIC RESET DURATION SET BY DIP-SWITCH
- T3: RANDOM DURATION OF MANUAL OR EXTERNAL RESET
- T4: DELAY OF RESET AFTER 230VCA RESTORING; ABOUT 20s

(A) IN CASE OF RESET WITH STILL FAULTY LINE THE DEVICE ENERGIZES AGAIN

MAINTENANCE SPECIFICATIONS

KIT ASSEMBLIES

FOR PHASE TO PHASE FAULT :

Nº1 FI/P/X DWG. 43911885

Nº3 TA/P DWG. 43911905

Nº1 BLINKING LAMP DWG. 43911951*

FOR PHASE TO PHASE FAULT + EARTH FAULT:

Nº1 FI/E/X DWG. 43911885

Nº2 TA/P DWG. 43911905

Nº1 TA/E DWG. 43911906

Nº1 BLINKING LAMP DWG. 43911951*

*optional

STORAGE

If the complex must be storage before use, please keep dry and repaired from cold and hot climates, respecting the original position of case. Move and take care to prevent injures.

OPERATING TEMPERATURE RANGE: -20°C ÷ +70°C

STORAGE TEMPERATURE: -40°C ÷ +85°C

RELATIVE HUMIDITY: 95% @ +40°C

BATTERY SPECIFICATIONS

TYPE: ER14505 Lithium thionyl chloride battery

NOMINAL CAPACITY: 2400mAh

NOMINAL VOLTAGE: 3,6 Vdc

STANDARD DISCHARGE CURRENT: 2mA

MAXIMUM CONTINUOUS CURRENT: 100mA

MAXIMUM PULSE CURRENT: 200mA

OPERATING TEMPERATURE RANGE: -55°C ÷ +85°C

STORAGE TEMPERATURE: +30°C Max (recommended)